

COMMERCIAL HEAVY DUTY



Product Specifications

Shape	Round
Seat Material	Polypropylene
Seat Form	Open front
Commercial Hinge	Yes
Bolt Material	Stainless steel
Hardware Material	Stainless Steel
Check Hinge	Yes
Cover	Yes
Custom Gasket	Yes
Color	White

Warranty 1 year limited warranty

Available Colors White,

Features

Antimicrobial

US: Antimicrobial additive inhibits the growth of stain and odor causing bacteria on this article.
 CDN: Contains CESA-MB8233 as a preservative for the protection of this article.

Fire Retardant

Includes fire retardant additive.

Commercial Hinge

Includes commercial grade hinges. One piece solid metal hinge pin and bolt over molded with plastic.

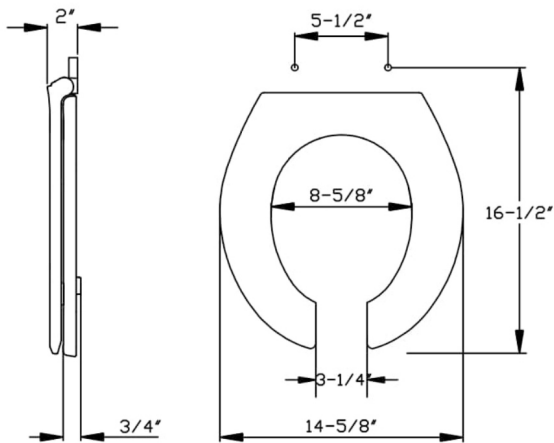

Dimensions shown are nominal and may vary within a range of tolerance. Product specifications are subject to change without notice.